

ELECTRICAL SPECIFICATIONS

Frequency Range	3.579 to 150.00Mhz
Operating Temp. Voltage	-10 to +70 deg. C standard
Storage Temp. Range	-20 to +125 deg. C
Frequency Tolerance @ 25 deg. C	+/- 100 ppm Standard
Frequency Stability	50 ppm Std. / over temp range
Load Cap (CL)	18 pF Standard
Drive Level	0.5mW
Shunt Capacitance	7pF Maximum
Aging @ 25 deg. C	+/-5ppm per year MAX
Insulation Resistance	500 Ohms Min @ 100vdc

EQUIVALENT SERIES RESISTANCE

Frequency (Mhz)	ESR MAX	Mode of Oscillation
3.579 to 3.999	150	Fund/AT
4.000 to 4.999	120	Fund/AT
5.000 to 5.999	100	Fund/AT
6.000 to 7.999	90	Fund/AT
8.000 to 9.999	70	Fund/AT
10.000 to 11.999	60	Fund/AT
12.000 to 14.999	50	Fund/AT
15.000 to 19.999	40	Fund/AT
20.000 to 27.000	30	Fund/AT
27.000 to 32.999	50	Fund/BT
33.000 to 40.000	40	Fund/BT
24.576 to 47.999	80	3rd Overtone
48.000 to 85.000	60	3rd Overtone

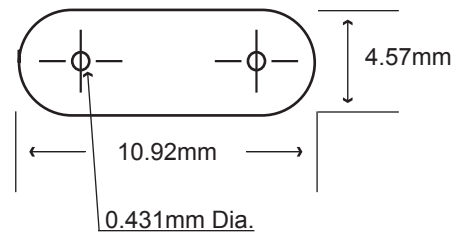
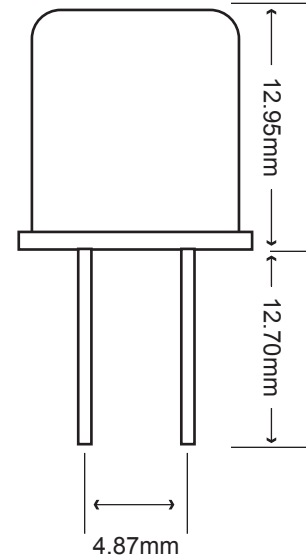

If you require custom specifications please contact:

CRYSTAL DYNAMICS
www.cdiusa.net

Part Number Guide

CDI-6S	7M6800	C	1	3	F = Fundamental	
CDI Prefix	Frequency	Tolerance/Stability	Operating Temp.	Load Cap.	Mode of Operation	Options
10 = UM1		A = 100/100 B = 50/100	1 = 0 ~ 70 deg. C	S = Series 6 = 12.5pF	F = Fundamental	G = 3rd Lead
5 = UM5		C = 50/50 D = 25/100	2 = -10 ~ 60 deg. C	1 = 50pF 7 = 10pF	3 = 3rd Overtone	B = Vinyl Sleeve
6 = HC49U		E = 30/50 F = 25/25	3 = -20 ~ 70 deg. C	2 = 32pF 8 = 7.5pF	5 = 5th Overtone	C = Insulator
6S = HC49US		G = 10/50 H = 10/25	4 = -40 ~ 85 deg. C	3 = 30pF X = Special	7 = 7th Overtone	X = Special
6-SMD= HC49US SMD		I = 10/10	S = Special	4 = 20pF 5 = 18pF	9 = 9th overtone	T = Tape & reel
572 = 7X5mm SMD		X = Special				
574 = 7X5mm SMD						
26 = 2X6mm						
38 = 3X8mm						
310 = 3X10mm						