

SPECIFICATIONS

Type	HCMOS
Frequency Range	3.5~70Mhz
Frequency Tolerance	+/-20ppm, +/-50ppm, +/-100ppm
Storage Temperature	-40 deg. C ~ +100 deg. C
Operating Temperature	0 ~ +70 deg. C Std.
Current Consumption	60mA Max
Rise and Fall Times	6nS Max
Duty Cycle	40/60%
Input Voltage	+5.0Vdc +/-0.5Vdc
Logic "0"	+0.5V max
Logic "1"	-0.5V max
Output Load	1-10 TTL or 30pF

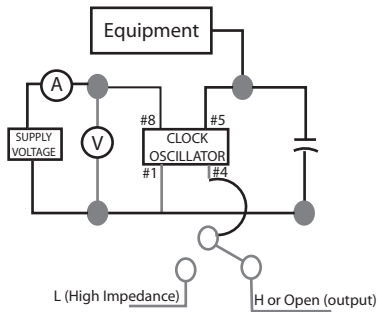
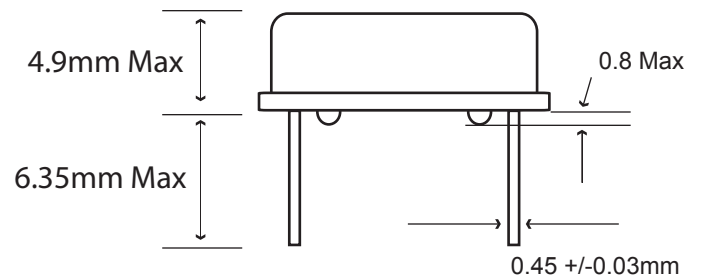
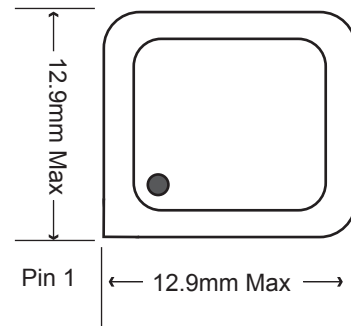
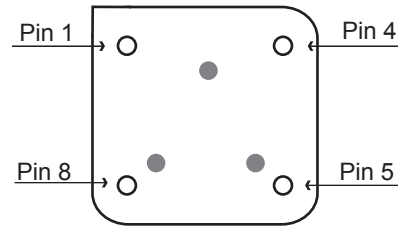

If you require custom specifications please contact:

CRYSTAL DYNAMICS
www.cdusa.net

Pin	Connection
1	E/D
7	GND
8	Output
14	Vcc

CDI Part Number Guide

CDI-HM	1	1	A	0		18M0000
CDI Prefix	Package	Voltage	Temperature Range	Tol/Stab	Options	Frequency
	1 = Half Size 2 = Full Size G = Gull Wing	1 = 5VDC 2 = 3.3VDC	A = 0~+70 C B = -20~+70 C C = -40~+85 C	0 = +/-100ppm 1 = +/-50ppm 2 = +/-25ppm	A = Tristate / Enable High D = Tight Symmetry (45/55)	